

xCAN (PRO iCAN, xDSD AND NANO iDSD BL)

BALANCED BUT NOT AS WE KNOW IT

PART 1. ACTIVELY GOES WHERE NONE HAVE GONE BEFORE

The new xCAN (and Pro iCAN, xDSD and nano iDSD BL) sport a dual-mono headphone amplifier with 3.5mm TRRS balanced wiring all the way to the amplifier.

This S-Balanced technology means that despite the amplifier being single-ended, this delivers all the benefits of balanced wiring.

Why did we feel the need to develop this? Let's take a look.

The problem with TRS connected headphones:

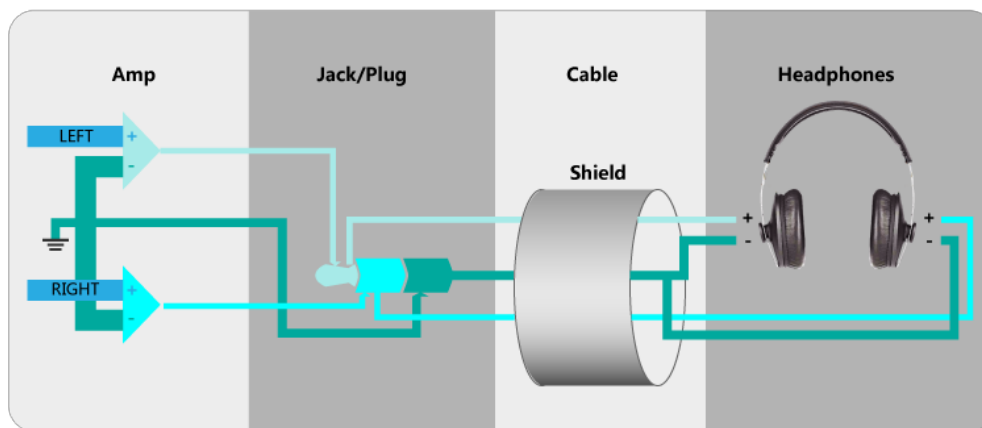

The left and right headphone share a single ground connection. This causes crosstalk and extra distortion. The lower the impedance of the headphone, the worse the problem. IEMs, in particular, are heavily affected.

Balanced connection (can be TRRS though, here shown with XLR):

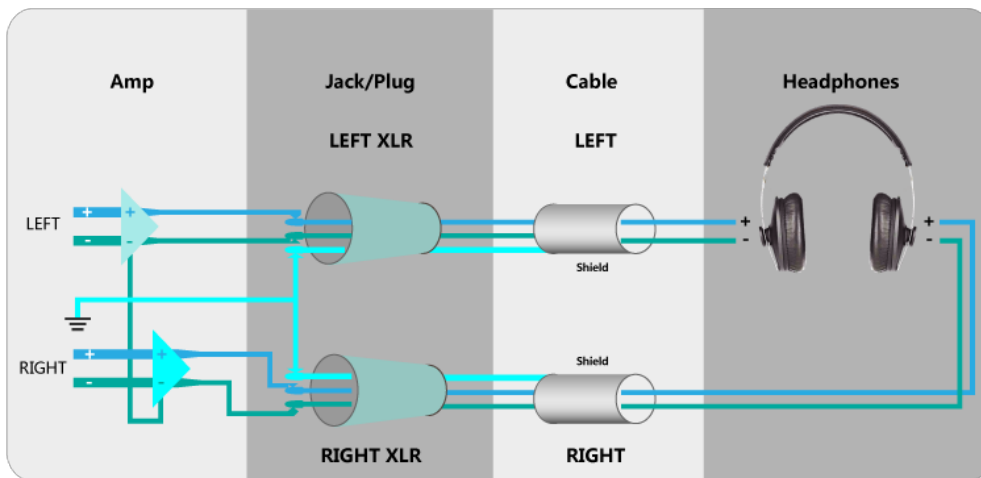

Left and right 'negative' are separate, the negative connection runs all the way to the separate amplifiers and no crosstalk/distortion happens.

Balanced output Amp:

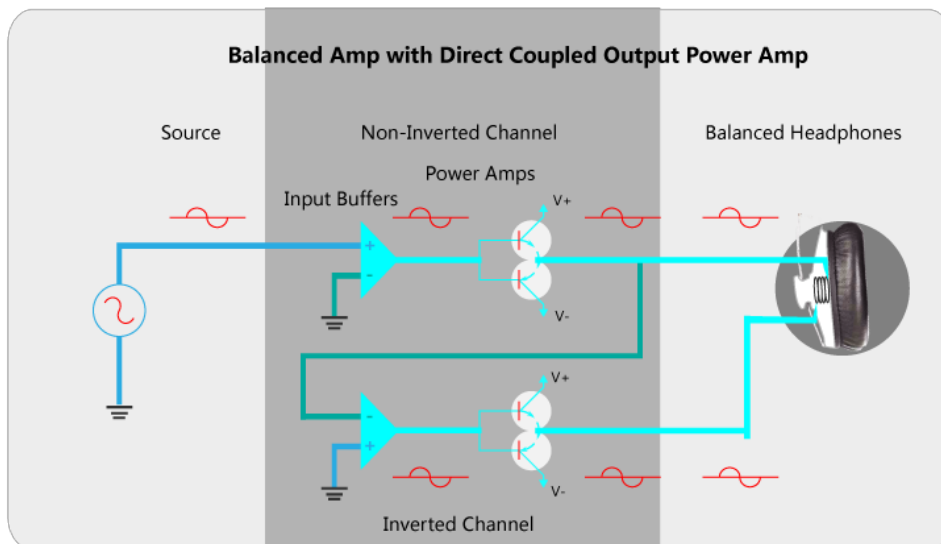

The second amplifier doubles both signal levels and noise/distortion, and so, such a balanced amplifier has more output but also MORE noise and distortion than an unbalanced amplifier. This perversely makes such a balanced connection LESS IDEALY-SUITED for IEMs. However, a dedicated negative wire per channel makes sure there is no crosstalk between the channels.

Plugging in unbalanced headphones with a TRS connector instead of TRRS will not be compatible, it will cause distorted sound and may damage the amplifier.

PART 2. THE S-BALANCED SOLUTION

(AS FOUND IN PRO iCAN, xCAN, xDSD AND NANO iDSD BL)

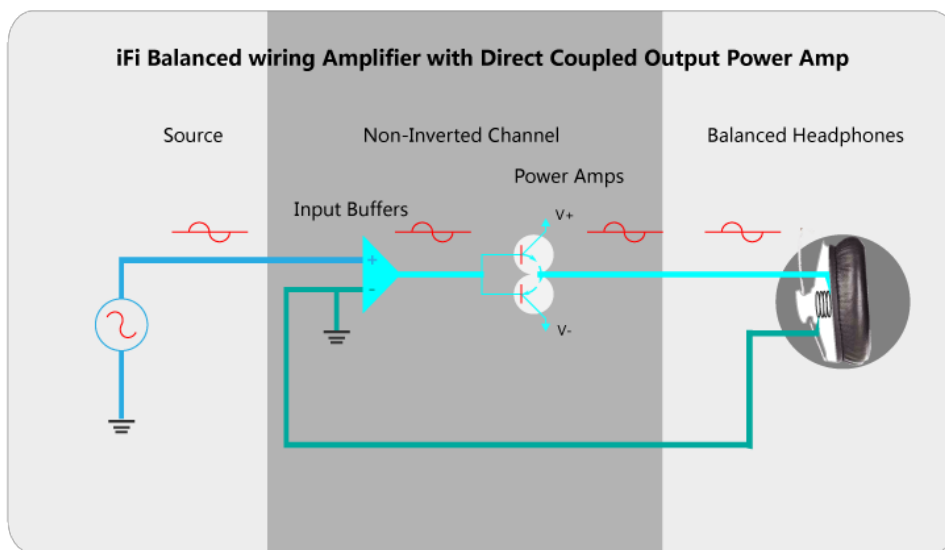

No second amplifier is used, neither are extra signal, noise, nor distortion added - perfect for sensitive IEMs. Further including the iEMatch technology extends compatibility with ultra-sensitive IEMs. A dedicated negative wire per channel all the way to each channel's amplifier's star-ground makes sure there is no crosstalk between the channels.

Plugging in unbalanced headphones with a TRS connector instead of TRRS will cause zero issues and, in fact, will still cut crosstalk by 50%, compared to using a TRS socket.

S-Balanced output works on TRS & TRRS headphones

It is fully compatible with and supports balanced wired headphones on TRRS 3.5mm and the Chinese 3.5PRO balanced wiring standard maintaining the channel separation. That is, after all, the point of S-Balanced.

It can also use 3.5mm TRS connections without problems.

'S-Balanced' is short for 'Single-Ended Compatible Balanced.'

<https://www.head-fi.org/threads/some-common-headphones-plug-wiring-for-balanced-audio.875730/>



We are compatible with Hifiman/LHLabs/3.5PRO/OPPO PM3 in the above on 3.5mm S-Balanced.

Balanced wiring delivers full benefits with lower noise and distortion (and lower output) than other balanced circuitry and is transparently compatible with TRS unbalanced headphones and headphones with microphones making sure neither Amp nor Headphone can be damaged.

Which is why 'S-Balanced' is so awesome and could only be invented by a Nicola Tesla level genius.

- Compatible with A&K/FiiO on 2.5mm Balanced
- Compatible with any 2.5mm Balanced equipped product compatible with A&K/FiiO

The key to the S-Balanced advantage is to understand the following:

- A balanced output includes two separate amplifiers
- All else being equal, two amplifiers contribute both noise and distortion
- Due the laws underpinning this, the output noise of the two balanced amplifiers MUST be at least 3dB greater (1.4 times) than that of the single amplifier
- The odd order (unpleasant or disharmonic) distortion of the two amplifiers for the same level on each amplifier summed will also be at least 3dB greater than the single amplifier.

So, why is it often said "Balanced has lower noise/greater SNR (signal to noise ratio)/greater dynamic range?"

Because balanced lines typically run at least at twice the signal level as well, so a 3dB noise advantage accrues at the new 6dB higher (2X) signal level. Pro systems typically run at least four to five times the signal level and will as a result have even greater gains in SNR IF OPERATED at this new higher level.

Why is this a problem with headphones?

Because a headphone or IEM connected balanced STILL has the same SPL per volt, so the signal level cannot be increased, so for the SAME signal level noise and distortion instead is increased, for less than ideal design as much as 9dB (almost 3X) over the unbalanced single amplifier case.

S-Balanced solves all this. Full balanced wiring, superior low noise and distortion and no problems if anything is plugged in wrong (Sony's engineers could have figured this out without the need to invent the 4.4mm Pentacon instead!).

Upshot. For line connections True Balanced (as per our Whitepaper https://ifi-audio.com/wp-content/uploads/2018/07/PART1_iCAN-PRO.pdf) at the higher signal level is superior.



Tech Notes

The design outlined in the paper as 1) will suffer the 9dB penalty in noise for headphone use however (and yes, it is precisely how the xCAN works).

The design we show as True Balanced will only suffer a 3dB disadvantage. S-Balanced suffers no disadvantage but has all benefits of Balanced for HEADPHONES and for HEADPHONES ONLY.

With S-Balanced and 3D+ & XBassII, we have pretty much game-changing tech.

All the benefits of balanced, with none of the drawbacks.

For further information, please contact: Victoria Pickles
press@ifi-audio.com / +44(0) 1704 227 204

About iFi

iFi audio is part of AGL and is headquartered in Southport, UK. It owns the hifi brand Abbingdon Music Research (AMR). They respectively design and manufacture portable and desktop 'ultra-fidelity' audio products and high-end audio 'home-based' components. The combined in-house hardware and software development team enables iFi audio and AMR to bring to market advanced audio products.